

Specification Sheet

Model No. : MTF0240QT-16

Description : 2.4 inch 240 x 320 Pixel Resolution
16/18 bit Paralle Interface TFT LCD Module
Option Resistance Touch Panel

History of Versions and Modifications

Version	Modifications	Date
V1.0	Generation first version	Jan 18,2016

CONTENTS

NO.	ITEM	PAGE
-	Cover	1
-	History of Versions and Modifications	2
-	contents	3
1	General Specifications	4
2	Functional block diagram	5
3	Outline Drawing	6
4	Absolute Maximum Ratings	7
5	LED backlight specification and Instruction Code	8
6	Viewing Direction	11
7	Electro-optical Units	12
8	Standard Specification for Reliability	13
9	Precautions for Use of LCD Modules	14

1.General Specifications

Item	Main LCD	Unit	Note
LCD Type	2.4' TFT LCD	-	
Display color	262K	-	
LCD Duty	1/320	-	
LCD Bias	-	-	
Viewing Direction	12:00	0 °Clock	
Viewing Area(W×H)	-	mm	
Active Area(W×H)	36.72X48.96	mm	
Number of Dots		-	
Dot Size(W×H)	-	mm	
Dot Pitch(W×H)		-	
Controller	ILI9341V	-	
V _{DD}	2.7~3.3V	V	
Outline Dimensions	Refer to outline drawing on next page		
Backlight	LED(white)	-	
Operating Temperature	-20~+70℃	-	
Storage Temperature	-30~+80℃	-	
Weight	TBD	g	
Data Transfer	16 /18Bits paralle	-	
Display Type	Transmissive type	-	

Note 1: Select by software, and color tune is slightly changed by temperature and driving voltage.

Note 2: TBD- To Be Determined.

Note 3: Requirements on Environmental Protection:RoHS

2. Functional block diagram

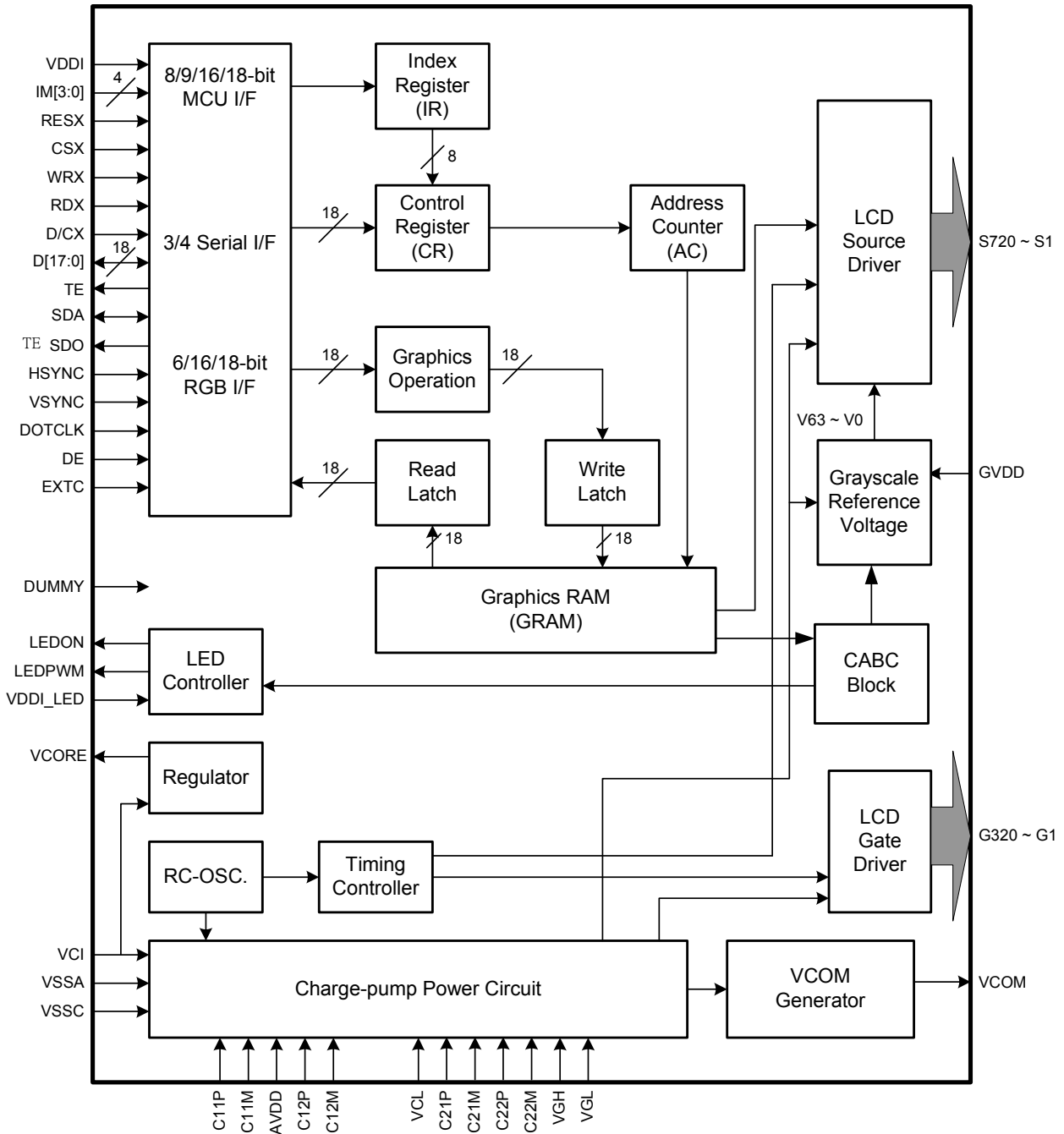

MODEL NO:MTF0240QT-16

3.Outline Drawing

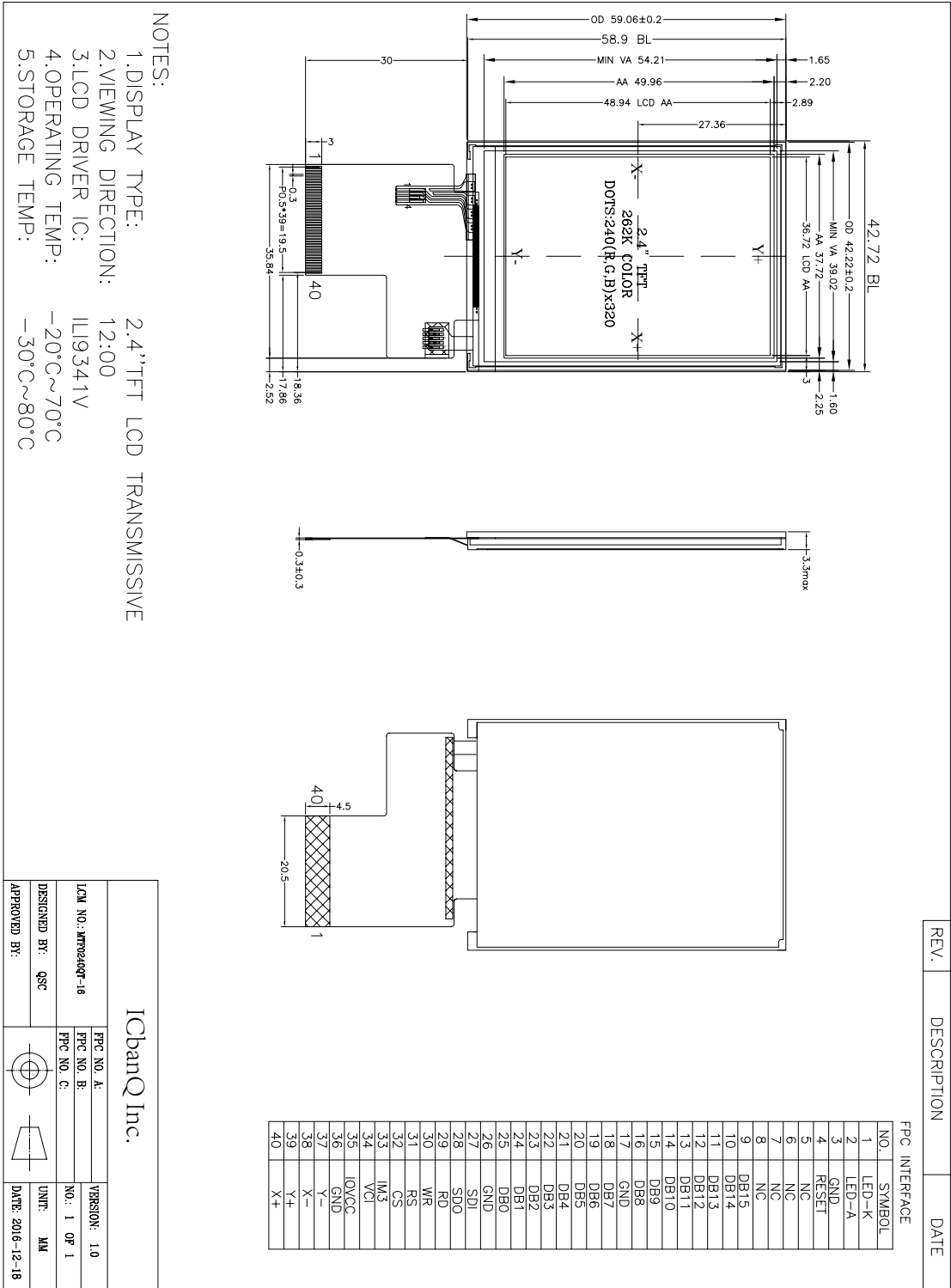

MODEL NO:MTF0240QT-16

4. Absolute Maximum Ratings(Ta=25 °C)

Item	Symbol	Min.	Max.	Unit	Note
Power Supply Voltage(1)	V _{BAT}	-	-	V	1,2
Power Supply Voltage(2)	V _{DD}	2.4	3.3	V	
Power Supply Voltage for Mail LCD	V _{op}	-	-	V	
Logic Signal Input Voltage	V _I	-0.3	V _{DD} +0.3	V	
Operating Temperature	T _{op}	-20	+70	°C	
S torage Temperature	T _{st}	-30	+80	°C	

Notes:

1. If the module is above these absolute maximum ratings. It may become permanently damaged. Using the module within the following electrical characteristic conditions are also exceeded, the module will malfunction and cause poor reliability.
2. V_{DD} > V_{SS} must be maintained.

5. LED Backlight Specification and Instruction Code

5.1 ABSOLUTE MAXIMUM RATINGS

(Ta=25°C.Unless specified,The Ambient temperature Ta=25°C)

Item	Symbol	Conditions	Rating	Unit
* Absolute maximum forward current	Ifm		150	mA
* Peak forward current	Ifp	1 msec Plus 10% Duty Cycle	100	mA
Reverse Voltage	Vr		5	V
* Power dissipation	Pd		510	mW
Operating Temperature Range	Topr		-30~+70	°C
Storage Temperature Range	Tstg		-40~+80	°C

5.2 ELECTRICAL-OPTICAL CHARACTERISTICS

(Ta=25°C.Unless specified,The Ambient temperature Ta=25°C)

Item	Symbol	min.	typ.	max.	Unit	Condition
Forward Voltage	Vf	3.0	3.2	3.4	V	If= 75 mA
Reverse Current	Ir			-	μA	Vr= 5 V
Dominant wave length	λD	X 0.26 Y 0.26		X 0.30 Y 0.30	nm	If= 75 mA
Spectral Line Half width	Δλ				nm	If= 75 mA
* Luminance	Lv	3000	-		cd/m ²	If= 75 mA

The luminance is the average value of 9 points, and
 The Lvmin./Lvmax. is more than 80%Typical
 The measurement instrument is BM-7 luminance
 Colorimeter.The aperture is ø 5 mm. lifetime=50000h

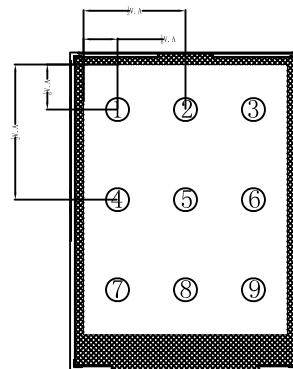

5.3 Interface Signal

Pin No.	Symbol	I/O	Description
1	LED-K	I	LED backlight Cathode
2	LED-A	I	LED backlight Anode
3	GND	I/O	Power ground
4	RESET	I	Reset signal pin
5	NC		No connection
6	NC		No connection
7	NC		No connection
8	NC		No connection
9	DB15	I/O	Date-Bus
10	DB14	I/O	
11	DB13	I/O	
12	DB12	I/O	
13	DB11	I/O	
14	DB10	I/O	
15	DB9	I/O	
16	DB8	I/O	
17	GND	P	
18	DB7	I/O	
19	DB6	I/O	
20	DB5	I/O	
21	DB4	I/O	
22	DB3	I/O	
23	DB2	I/O	
24	DB1	I/O	
25	DB0	I/O	
26	GND	I/O	
27	SDI	I/O	Serial data input
28	SDO	I	No connection
29	RD	I	Read execute control pin

MODEL NO:MTF0240QT-16

Pin No.	Symbol	I/O	Description
30	WR	I	Write execute control pin
31	D/C	I	Register select signal
32	CS	I	Chip select signal
33	IM3	I	If use Parallel Interface ,this pin should be connected to VDDI
34	VCI	I/O	Liquid crystal analog circuit power supply
35	IOVCC	I/O	power supply
36	GND	I/O	Power Ground
37	Y-	O	Touch panel Y-
38	X-	O	Touch panel X-
39	Y+	O	Touch panel Y+
40	X+	I/O	Touch panel X+

6.Viewing Direction

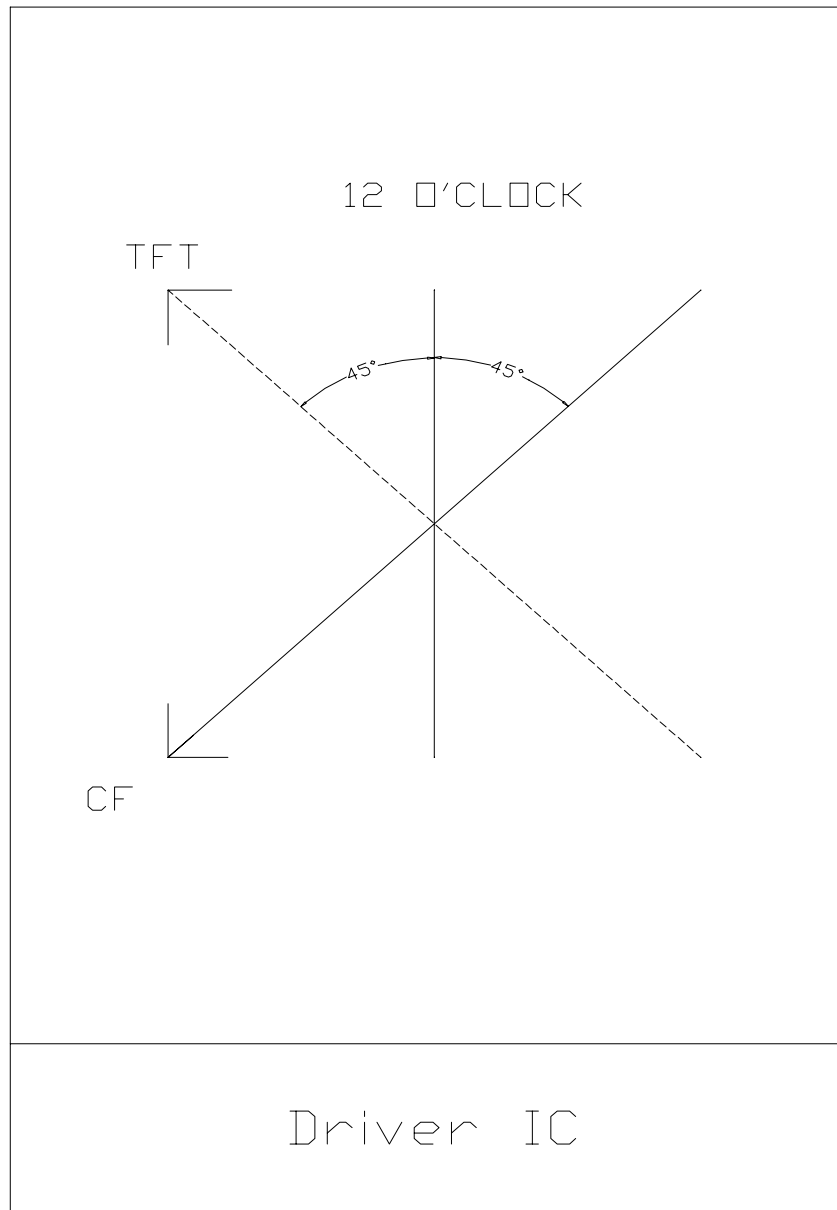

Viewing angle 12o'clock

7. Electro-optical Units

ITEM	SYMBOL	CONDITION	MIN.	TYP.	MAX.	UNIT	REMARK
Transmittance	T			4.7		%	
Contrast Ratio	CR	*1)		250	-		Note 3
Response Time	Tr+ Tf	*3)	-	25		ms	Note 4
Viewing Angle	Vertical	θ *2)	$CR \geq 10$	80	100	-	Note 5
	Horizontal	ϕ *2)		90	110	-	
Color Filter Chromacicity	White	x	$\theta = \phi = 0^\circ$	(0.288)	(0.308)	(0.328)	Note 6
		y		(0.322)	(0.342)	(0.362)	
		Y		(27.488)	(30.488)	(33.488)	
	Red	x	$\theta = \phi = 0^\circ$	(0.632)	(0.652)	(0.672)	
		y		(0.310)	(0.330)	(0.350)	
		Y		(15.153)	(18.153)	(21.153)	
	Green	x	$\theta = \phi = 0^\circ$	(0.297)	(0.317)	(0.337)	
		y		(0.555)	(0.575)	(0.595)	
		Y		(54.617)	(58.617)	(62.617)	
	Blue	x	$\theta = \phi = 0^\circ$	(0.117)	(0.137)	(0.157)	
		y		(0.112)	(0.132)	(0.152)	
		Y		(11.694)	(14.694)	(17.694)	
NTSC			-	(61%)	-		

Note 1. Ambient condition : 25°C ± 2°C , 60 ± 10% RH , under 10 Lux in the darkroom .

Note 2. Measure device : BM-5A (TOPCON) , viewing cone= 1° , I_L=20mA .

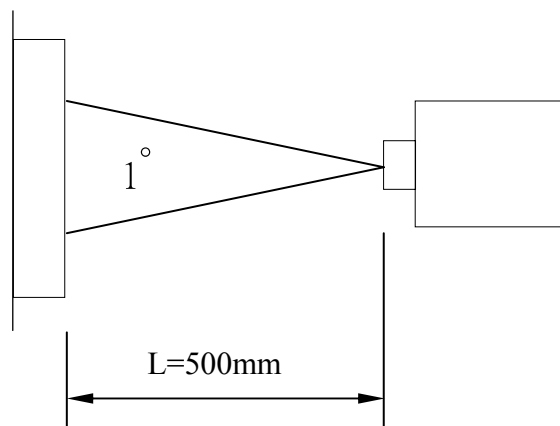

Note 3. Definition of Contrast Ratio :

$$CR = \text{White Luminance (ON)} / \text{Black Luminance (OFF)}$$

Note 4. Definition of response time : The response time is defined as the time interval between the 10% and 90% amplitudes.

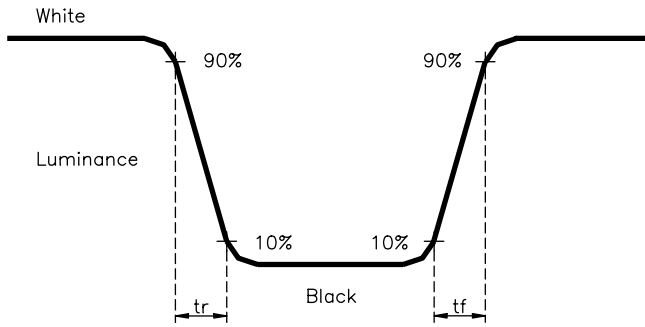

Note 5. Definition of view angle(θ , ψ) :

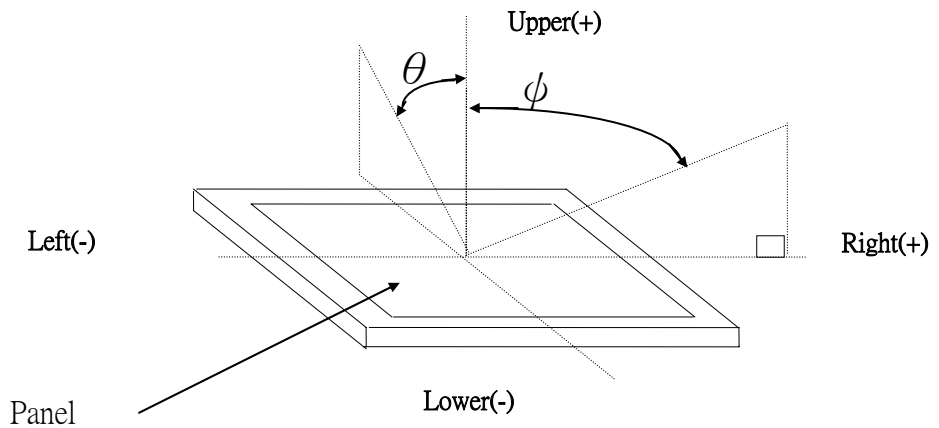

Note 6. Light source: C light.

MODEL NO:MTF0240QT-16

8. Standard Specification for Reliability

No.	Test Item	Test condition	Criterion
1	High Temperature Storage	80°C±2°C 96H Restore 4H at 25°C	1. After testing, cosmetic defects should not happen. 2. Total current consumption should not be over 10% of initial value.
2	Low Temperature Storage	-30°C±2°C 96H Restore 4H at 25°C	
3	High Temperature Operation	70°C±2°C 48H Restore 4H at 25°C	
4	Low Temperature Operation	-20°C±2°C 48H Restore 4H at 25°C	
5	High Temperature /Humidity Storage	40°C±2°C 90%RH 48H	
6	Temperature Cycle	-30°C——25°C——80°C 5min 30min ——25°C , 5min after 10cycle, Restore 4H at 25°C	
7	Vibration Test (package state)	10Hz~150Hz, 100m/s ² , 120min	Not allowed cosmetic and electrical defects.
8	Shock Test (package state)	Half- sine wave, 300m/s ² , 18ms	
9	Atmospheric Pressure Test	25kPa 16H Restore 2H	
10	Cable Bending Test	Bending area and angle follow design document requirement	More than 50000 times

9. Precautions for Use of LCD Modules

9.1 Handling Precautions

- 9.1.1 The display panel is made of glass. Do not subject it to a mechanical shock by dropping it from a high place, etc.
- 9.1.2 If the display panel is damaged and the liquid crystal substance inside it leaks out, be sure not to get any in your mouth, if the substance comes into contact with your skin or clothes, promptly wash it off using soap and water.
- 9.1.3 Do not apply excessive force to the display surface or the adjoining areas since this may cause the color tone to vary.
- 9.1.4 The polarizer covering the display surface of the LCD module is easily scratched. Handle this polarizer carefully.
- 9.1.5 If the display surface is contaminated, breathe on the surface and gently wipe it with a soft dry cloth. If still not completely clear, moisten cloth with one of the following solvents:
- Isopropyl alcohol
 - Ethyl alcohol
- Solvents other than those mentioned above may damage the polarizer. Especially, do not use the following:
- Water
 - Ketone
 - Aromatic solvents
- 9.1.6 Do not attempt to disassemble the LCD Module.
- 9.1.7 If the logic circuit power is off, do not apply the input signals.
- 9.1.8 To prevent destruction of the elements by static electricity, be careful to maintain an optimum work environment.
- a. Be sure to ground the body when handling the LCD Modules.
 - b. Tools required for assembly, such as soldering irons, must be properly ground.
 - c. To reduce the amount of static electricity generated, do not conduct assembly and other work under dry conditions.

- d. The LCD Module is coated with a film to protect the display surface. Be care when peeling off this protective film since static electricity may be generated.

9.2 Storage precautions

9.2.1 When storing the LCD modules, avoid exposure to direct sunlight or to the light of fluorescent lamps.

9.2.2 The LCD modules should be stored under the storage temperature range. If the LCD modules will be stored for a long time, the recommend condition is:

Temperature : 0°C ~ 40°C

Relatively humidity: ≤80%

9.2.3 The LCD modules should be stored in the room without acid, alkali and harmful gas.

9.3 The LCD modules should be no falling and violent shocking during transportation, and also should avoid excessive press, water, damp and sunshine.